

ASPHALT OR HARDENED CONCRETE SITE

Find a smooth, level location on the asphalt. Fill the voids on open mixes with sand or cement. **The gauge base must rest on the asphalt, not the fill material!** Ensure that the gauge does not “rock.” It must remain level and steady. If the gauge rocks, find a more suitable test site. If taking a measurement around a core, the gauge may be moved a few inches away from the hole to level the gauge.

OFFSET FUNCTION

The gauge can be adjusted using an offset. The gauge applies the offset to measurements until the offset is disabled or the gauge is turned off. The 3430 gauge provides three offsets: *density*, *moisture*, and *trench*.

Press **(SPECIAL)** to access the *Special* functions. Then press the down arrow key once to access the *Offset* function.

DENSITY OFFSET

To select the density offset from the *Offset* function display, press **(START/ENTER)**. To enable the density offset, press **(ON/YES)**. Input the difference between the gauge and actual density readings. To input a minus (–) sign (for a negative offset), press the down arrow key *first*. To scroll through the numerals, use the up and down arrow keys. To select the next digit and/or exit, press **(START/ENTER)**. When all digits are entered, the gauge will enable the offset.

MOISTURE OFFSET

To select moisture offset from the *Offset* function display, press the down arrow key once and press **(START/ENTER)**. To enable the moisture offset, press **(ON/YES)**. Input the offset. To input a minus (–) sign (for a negative offset), press the down arrow key *first*. To scroll through the numerals, use the up and down arrow keys. To select the next digit and/or exit, press **(START/ENTER)**. When all digits are entered, the gauge will enable the offset.

TRENCH OFFSET

To enable a trench offset, choose *Trench* from the *Offset* options under the *Special* functions display. The gauge will request both the *Dens Const* and *Moist Const* values. The procedure for entering these values is the same as for moisture and density offsets, **ignoring the ± sign on the display**.

To perform a trench offset, take the daily standard count outside the trench and record the density (*DS*) and moisture (*MS*) values. Place the gauge on the reference standard block in the trench the same distance from the wall as the anticipated

readings. Set the count time to four minutes. With the source rod in the **SAFE** position, press **(START/ENTER)**. After the count, record the trench density DC_{Trench} and moisture MC_{Trench} counts. To determine the offsets, subtract the daily standard counts from the trench counts.

TESTING AND MEASUREMENT

Before taking any measurement, the operator must do several things. Check the count time and depth. Enter the Marshall or Proctor value. Prepare the test site.

After taking readings, lift the gauge from the test site by the source rod handle. This returns the source rod to the **SAFE** position. When not taking readings, always keep the source rod in the **SAFE** position.

SOIL MODE

The *Soil* mode is automatically selected when a Proctor value is enabled.

Place the gauge over the test site. Release the gauge handle and push it down until the source rod is in the correct position. Ensure that the indexer engages the notch in the index rod. To take a measurement, press **(START/ENTER)**.

After the measurement, the gauge displays the measurement results in a series of six screens. Use the up and down arrow keys to scroll through the various displays.

ASPHALT MODE

The *Asphalt* mode is automatically selected when a Marshall value is enabled.

Place the gauge over the test site. Release the gauge handle and push it into the backscatter position. Ensure that the indexer engages the notch in the index rod. Gently tap the handle down to ensure proper source rod seating. Set the depth to *Backscatter*. To take a measurement, press **(START/ENTER)**.

After the measurement, the gauge displays the measurement results in a series of six screens. Use the up and down arrow keys to scroll through the various displays.

RECALL FUNCTION

Although the 3430 gauge does not store multiple readings, the *Recall* function enables the operator to view the data from the **last** reading. Press **(SPECIAL)** to access the *Special* functions, then press **(START/ENTER)**. The gauge displays the data from the last measurement in a series of six screens. Use the up and down arrow keys to scroll through the various displays.

Model 3430

Surface Moisture-Density Gauge

QUICK REFERENCE CARD



Troxler Electronic Laboratories, Inc.
3008 Cornwallis Road
P.O. Box 12057
Research Triangle Park, NC 27709
Tel (919) 549-8661 Fax (919) 549-0761

PN 109229
September 1999
Edition 1.0

GAUGE START UP

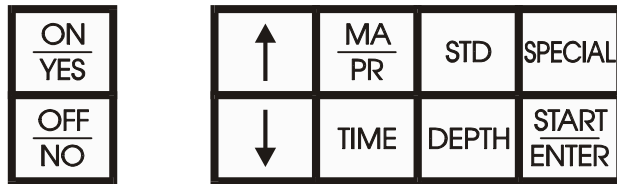

Model 3430 Keypad

NOTE

The operator should wear a dosimeter or radiation badge when working with the 3430 Surface Moisture-Density Gauge.

Press **<ON/YES>**. The gauge performs an LCD test and a 300-second self-test. Following the self-test, the gauge enters the *Ready* mode. The display is:

```
<READY> xx min
Depth: xx inches
```

The first line of the display indicates the current *count time*. The second line indicates the selected source rod depth.

GAUGE SETUP

COUNT TIME

To change the current count time (length of measurement), press **<TIME>**. Use the up and down arrow keys to scroll through the available count times. When the desired count time is displayed, press **<START/ENTER>**.

DEPTH

To change the depth of measurement, press **<DEPTH>**. Use the up and down arrow keys to scroll through the available measurement depths. When the desired depth is displayed, press **<START/ENTER>**.

MODE (MARSHALL/PROCTOR)

The 3430 gauge may be used on construction materials (soils, asphalt, concrete, and so on). To select the *Soil* mode, enter or activate a Proctor value. To select the *Asphalt* mode, enter or activate a Marshall value. The gauge can store one Marshall and one Proctor value.

NOTE

To measure concrete, use either the *Asphalt* or *Soil* mode. For moisture results, select the *Soil* mode. For density measurement only, select the *Asphalt* mode.

To enter or activate a Marshall or Proctor value, press **<MA/PR>**. The gauge displays one of the following:

```
MA: xxx (↑↓)
Change MA value?
```

```
PR: xx (↑↓)
Change PR value?
```

To switch from a Marshall to a Proctor value, or vice versa, use the arrow keys.

To activate the displayed value, press **<OFF/NO>**.

To change the displayed value, press **<ON/YES>**. The first digit of the value will flash. Use the arrow keys to scroll through the possible entries (0 – 9 and .). When the correct value for the current digit is displayed, press **<START/ENTER>**. The gauge will proceed to the next digit to the right.

When the value entry is complete, the gauge activates the entered value and returns to the *Ready* mode.

THE STANDARD COUNT

To compensate for the source decay and to check proper operation of the gauge, take a standard count daily.

Place the reference standard block on a dry, flat surface of asphalt, concrete, or compacted soil at least 10 cm (4 in) thick. The location should be at least 3 m (10 ft) from any building or vertical structure and 10 m (33 ft) from any other nuclear gauge or radioactive source.

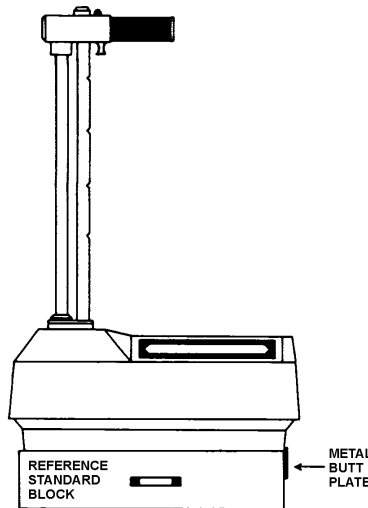

Ensure that the top surface of the reference standard block and bottom of the gauge are clean of debris. As shown at left, place the gauge between the grooves on the reference standard block. Place the source rod on your left and the right side of the gauge against the metal butt plate on the block. Ensure that the source rod is in the **SAFE** position.

Press **<STD>**. The gauge displays the last standard count. To take a new standard count, press **<ON/YES>**. With the gauge in the standard count position, press **<START/ENTER>** to begin the standard count.

After taking the standard count, the gauge displays the results. Troxler recommends that the operator keep a daily log of the standard count results, see Appendix E of the Model 3430 *Manual of Operation and Instruction* (user manual). For more information on taking the standard count, refer to Chapter 3 of the user manual.

SITE PREPARATION

To ensure measurement accuracy, properly prepare the test site before taking gauge measurements.

SOIL SITE

CAUTION
Safety glasses must be worn during this procedure.

Place the scraper plate on the test surface. Smooth the area by sliding the plate back and forth. Lift the plate from the surface and fill any voids or depressions. Replace the plate and press down slightly to further level the surface.

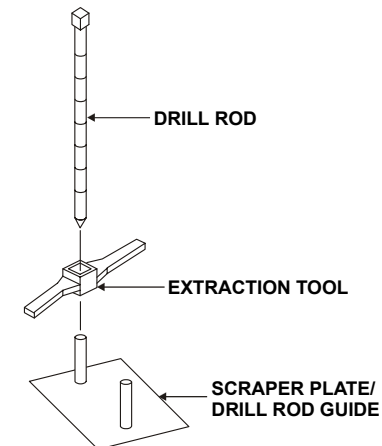

As shown at left, put the drill rod through the extraction tool. Put the drill rod through one of the guides on the scraper plate. Place the drill rod assembly on the test site. **Wearing safety glasses**, step on the scraper plate and hammer the drill rod at least 50 millimeters (2 in) deeper than the desired test depth. The drill rod increments include the additional

depth. Mark the test area. Remove the drill rod by pulling straight up on the drill rod extraction tool. **Do not loosen the drill rod by moving it from side-to-side.**

Place the gauge on the smoothed surface. Insert the source rod into the hole. Lower the source rod to the correct depth and release the trigger. A *click* should be heard when the source rod is locked into position. Gently slide the gauge toward the keypad so the source rod touches the side of the hole.